

**solaire**  
A Lagnuvo Initiative

Global: +91 1800 8338 666

 [www.solairefuture.com](http://www.solairefuture.com)

 [info.solaire@lagnuvo.com](mailto:info.solaire@lagnuvo.com)

# AELIO+HS51

49.9kW/50kW/60kW/61kW  
25.6kWh~399kWh

SolaX Split C&I Energy Storage Solution

# X3-AELIO



## Flexible Configuration

- Customizable battery setup: batteries can be flexibly configured according to customer site requirements, supporting indoor, outdoor and stacked installations
- Parallel operation: supports up to 10 parallel systems, meeting power requirements from 49.9 kW to 600 kW
- Battery options: two battery choices available
- PV oversizing: supports up to 200% PV oversizing



## Safe and Reliable

- Three-Phase unbalance: Inverter supports 100% three-phase unbalance
- Long-Term overload: inverter supports 110% long-term overload
- Seamless switching: inverter supports 10ms on-grid/off-grid switching
- Off-Grid overload: inverter supports 150% off-grid overload



## Intelligent and Convenient

- Remote monitoring: supports web/app remote data viewing and remote OTA updates.
- Versatile operating modes: supports various operating modes to meet different application scenarios such as self-consumption, peak shaving, and demand management.
- VPP Integration: supports VPP applications through IEEE2030.5, OpenADR※
- Generator control: work seamlessly with generator to save fuel and back up

	X3-AELIO-49.9K	X3-AELIO-49.9K-P	X3-AELIO-50K	X3-AELIO-60K	X3-AELIO-61K
<b>PV INPUT</b>					
Max. recommended PV array power	100 kWp	120 kWp	100 kWp	120 kWp	
Max. PV input voltage <sup>①</sup>	1000 V				
Rated PV input voltage	650 V				
MPPT voltage range <sup>②</sup>	160 ~ 950 V				
Start-up voltage	180 V				
No. of MPP trackers / strings per MPP tracker	5 / 2	6 / 2	5 / 2	6 / 2	
Max. input current per MPPT	40 A				
Max. input short circuit current per MPPT	50 A				
<b>AC INPUT &amp; OUTPUT (ON-GRID)</b>					
Rated output power	49.9 kW	49.9 kW	50 kW	60 kW	61 kW
Rated output current	75.7 A @ 220 V 72.4 A @ 230 V	75.7 A @ 220 V 72.4 A @ 230 V	75.8 A @ 220 V 72.5 A @ 230 V	91.0 A @ 220 V 87.0 A @ 230 V	92.5 A @ 220 V 88.5 A @ 230 V
Max. output apparent power	49.9 kVA	49.9 kVA	55.0 kVA	66.0 kVA	66.0 kVA
Max. output continuous current	75.7 A @ 220 V 72.4 A @ 230 V	75.7 A @ 220 V 72.4 A @ 230 V	83.4 A @ 220 V 79.8 A @ 230 V	100.0 A @ 220 V 95.7 A @ 230 V	100.0 A @ 220 V 95.7 A @ 230 V
Rated AC voltage	3 / N / PE, 220 / 380 V 3 / N / PE, 230 / 400 V				
Rated AC frequency	50 Hz / 60 Hz				
AC frequency range <sup>③</sup>	50 ± 5 Hz / 60 ± 5 Hz				
Adjustable power factor range	~ 1 (0.8 lagging to 0.8 leading)				
THDi (rated power)	< 3%				

## X3-AELIO-49.9K

## X3-AELIO-49.9K-P

## X3-AELIO-50K

## X3-AELIO-60K

## X3-AELIO-61K

BATTERY					
Battery type	LFP				
Battery voltage range	180 ~ 820 V				
Max. charge / discharge current	160 A (80 A × 2)				
EPS (OFF-GRID) OUTPUT					
Rated EPS output voltage, frequency	3 / N / PE, 220 / 380 V, 50 Hz / 60 Hz 3 / N / PE, 230 / 400 V, 50 Hz / 60 Hz				
Rated EPS output power	49.9 kVA	49.9 kVA	50.0 kVA	60.0 kVA	61.0 kVA
Max. EPS output power	75 kVA, 10s	75 kVA, 10s	75 kVA, 10s	90 kVA, 10s	90 kVA, 10s
Switchover time	< 10 ms				
EFFICIENCY					
Max. efficiency	98.0%				
European efficiency	97.2%				
ENVIRONMENT LIMIT					
Ingress protection	IP66				
Operating temperature range	-35 ~ 60°C (derating +45°C)				
Max. operating altitude	3000 m				
Relative humidity	0 ~ 100% RH (condensing)				
Overvoltage category	Mains: III, Battery: II, PV: II				
GENERAL					
Dimensions (W × H × D)	670 × 820 × 257 mm				
Net weight	< 100 kg	< 105 kg	< 100 kg	< 105 kg	< 105 kg
Cooling concept	Smart air cooling				
Communication interfaces	RS485-Meter, RS485-Monitor, RS485-Parallel (daisy-chain), CAN-BMS, CAN-Parallel (daisy-chain), USB, DI×2, DO×1, RCR (DI×4), DRM				
Topology	Non-isolated				
Certificates and approvals	CE, VDE4105, G99, AS4777, EN50549, CEI 0-21, IEC61727, PEA/MEA, NRS-097-2-1, RD1699, TOR				
PROTECTION					
Over / under voltage protection	Yes				
DC isolation protection	Yes				
DC reverse-polarity protection	Yes				
Grid monitoring	Yes				
DC injection monitoring	Yes				
Back feed current monitoring	Yes				
Residual current detection	Yes				
Over temperature protection	Yes				
Active anti-islanding method	Frequency shift				
Surge protection (DC / AC)	DC: Type II, AC: Type II				
Arc-fault circuit interrupter (AFCI)	Optional				
AC auxiliary power supply (APS)	Built-in				

① The maximum input voltage is the upper limit of the DC voltage. Any higher input DC voltage would probably damage inverter

② Input voltage exceeding the MPPT voltage range may triggers inverter protection

③ The AC frequency range may vary from different country codes

# TSYS-HS51



T-HS25.6 T-HS30.7 T-HS35.8 T-HS40.9 T-HS46.0 T-HS51.2 T-HS56.3 T-HS61.4 T-HS66.5

SYSTEM SPECIFICATION									
Number of modules	5	6	7	8	9	10	11	12	13
Rated energy	25.6 kWh	30.7 kWh	35.8 kWh	40.9 kWh	46.0 kWh	51.2 kWh	56.3 kWh	61.4 kWh	66.5 kWh
Usable energy (90% DOD) <sup>①</sup>	23.0 kWh	27.6 kWh	32.2 kWh	36.8 kWh	41.4 kWh	46.0 kWh	50.6 kWh	55.2 kWh	59.8 kWh
Rated voltage	256.0 V	307.2 V	358.4 V	409.6 V	460.8 V	512.0 V	563.2 V	614.4 V	665.6 V
Operation voltage range	212 ~ 289 V	255 ~ 347 V	297 ~ 405 V	340 ~ 463 V	382 ~ 520 V	424 ~ 578 V	467 ~ 636 V	509 ~ 694 V	552 ~ 750 V
Rated operation current <sup>②</sup>	60 A								
Maximum operation current <sup>②③</sup>	70 A								
Rated power <sup>③</sup>	15.4 kW	18.4 kW	21.5 kW	24.6 kW	27.6 kW	30.7 kW	33.8 kW	36.9 kW	39.9 kW
Max. power <sup>③</sup>	17.9 kW	21.5 kW	25.1 kW	28.7 kW	32.3 kW	35.8 kW	39.4 kW	43.0 kW	46.6 kW
Depth of discharge	90%								
Communication interfaces	CAN + RS485								
Dimensions (W x H x D)	600 x 1125 x 376 mm	600 x 1293 x 376 mm	600 x 1461 x 376 mm	600 x 1629 x 376 mm	600 x 957 x 376 mm + 600 x 1125 x 376 mm	600 x 1125 x 376 mm + 600 x 1125 x 376 mm	600 x 1293 x 376 mm + 600 x 1125 x 376 mm	600 x 1293 x 376 mm + 600 x 1293 x 376 mm	600 x 1461 x 376 mm + 600 x 1293 x 376 mm
BMS									
Model	TBMS-S51-8								
Dimensions (W x H x D)	600 x 225 x 376 mm								
Net weight	18.5 kg								
BATTERY MODULE									
Model	TB-HS51								
Battery type	LFP								
Cycle life (90% DOD)	>6000 cycles								
Module capacity	5.1 kWh								
Dimensions (W x H x D)	600 x 168 x 376 mm								
Net weight	46 kg								
Installation type	Stackable								
SERIES BOX									
Dimensions (W x H x D)	600 x 225 x 376 mm								
Net weight	15 kg								
GENERAL SPECIFICATION									
Installation	Floor mounting								
Charge temperature	-30 ~ +53°C (with heating function)				0 ~ +53°C (without heating function)				
Discharge temperature	-30 ~ +53°C (with heating function)				-20 ~ +53°C (without heating function)				
Relative humidity	4 ~ 100% RH (non-condensing)								
Altitude	< 3000 m								
Environment	Outdoor / indoor								
Ingress protection	IP66								
STANDARD									
Certifications	IEC62619, IEC62040, EN62477, VDE 2510								
Transport testing requirement	UN38.3								

① Test conditions: 90% DOD, 0.2C charge & discharge @ 25°C

② Max. charge / discharge current may be variant with different inverter models

③ Nominal / maximum operation current and rated / maximum power derating will occur related to temperature or SOC

# BATTERY MODULE COMBINATION TABLE

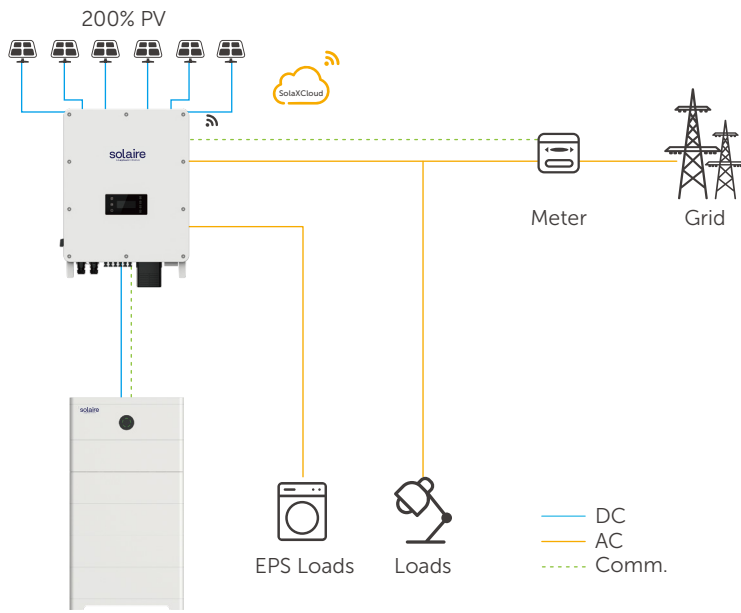

Battery port 1	Battery port 2	Battery capacity[kWh]
BMSx1+HS51x5	-	25.6
BMSx1+HS51x6	-	30.7
BMSx1+HS51x7	-	35.8
BMSx1+HS51x8	-	40.9
BMSx1+HS51x9	-	46
BMSx1+HS51x10	-	51.2
BMSx1+HS51x11	-	56.3
BMSx1+HS51x12	-	61.4
BMSx1+HS51x13	-	66.5
BMSx1+HS51x5	BMSx1+HS51x5	51.2
BMSx1+HS51x6	BMSx1+HS51x6	61.4
BMSx1+HS51x7	BMSx1+HS51x7	71.6
BMSx1+HS51x8	BMSx1+HS51x8	81.8
BMSx1+HS51x9	BMSx1+HS51x9	92
BMSx1+HS51x10	BMSx1+HS51x10	102.4
BMSx1+HS51x11	BMSx1+HS51x11	112.6
BMSx1+HS51x12	BMSx1+HS51x12	122.8
BMSx1+HS51x13	BMSx1+HS51x13	133

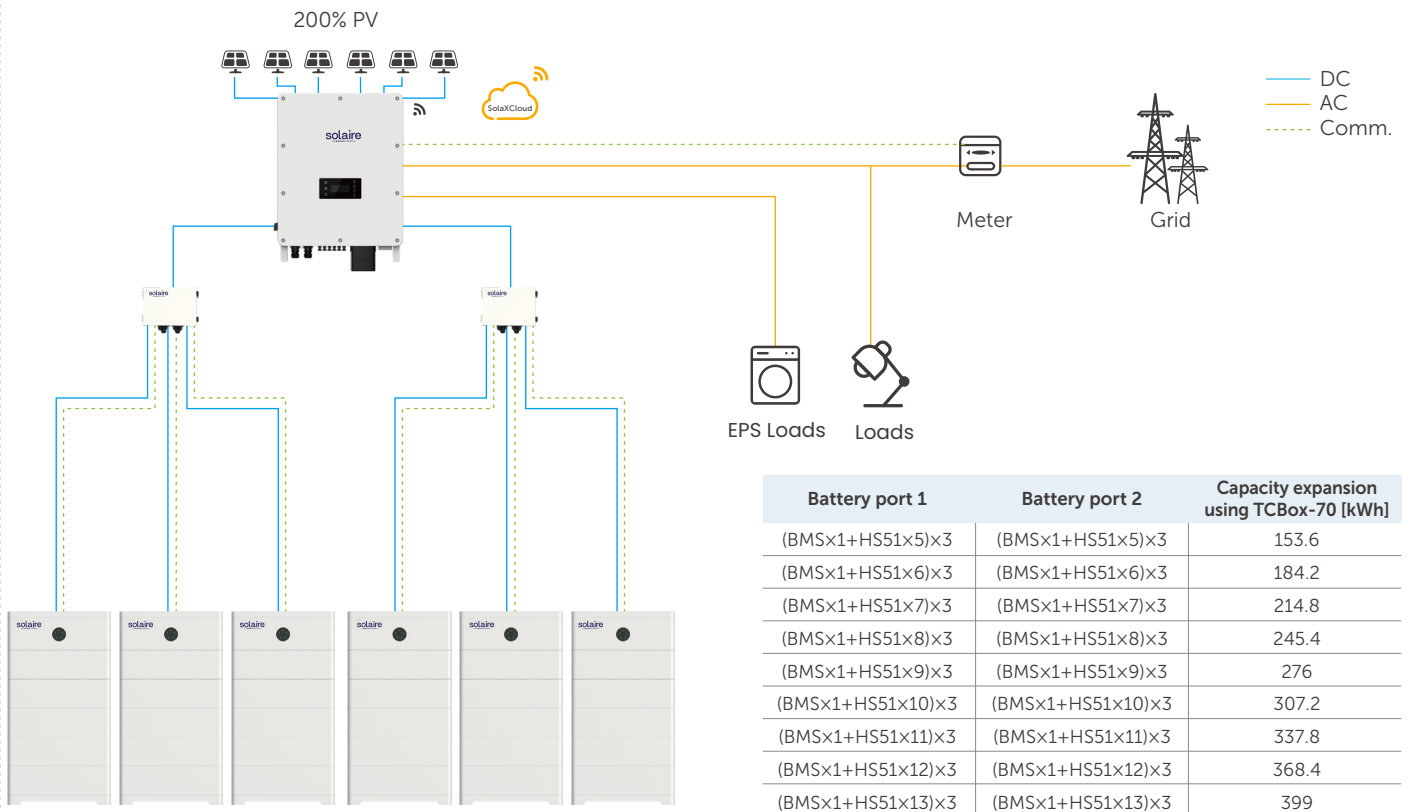

Battery port 1	Battery port 2	Capacity expansion using TCBox-70 [kWh]
(BMSx1+HS51x5)x3	(BMSx1+HS51x5)x3	153.6
(BMSx1+HS51x6)x3	(BMSx1+HS51x6)x3	184.2
(BMSx1+HS51x7)x3	(BMSx1+HS51x7)x3	214.8
(BMSx1+HS51x8)x3	(BMSx1+HS51x8)x3	245.4
(BMSx1+HS51x9)x3	(BMSx1+HS51x9)x3	276
(BMSx1+HS51x10)x3	(BMSx1+HS51x10)x3	307.2
(BMSx1+HS51x11)x3	(BMSx1+HS51x11)x3	337.8
(BMSx1+HS51x12)x3	(BMSx1+HS51x12)x3	368.4
(BMSx1+HS51x13)x3	(BMSx1+HS51x13)x3	399

\* TCBox is under development.

# solaire

A L agnuvo Initiative

**Powering India's Solar Future**

[www.solairefuture.com](http://www.solairefuture.com)

Global: +86 571-56260008  
+48 662 430 292

AU: +61 1300 476 529  
DE: +49(0)6142 967 3009

UK: +44 2476 586998  
NED:+31 (0) 8527 37932

[info@solaxpower.com](mailto:info@solaxpower.com)  
[service@solaxpower.com](mailto:service@solaxpower.com)

*V1.4 Information may be subject to modify without notice.  
650.00116.00*