

BATTERY MODULE COMBINATION TABLE

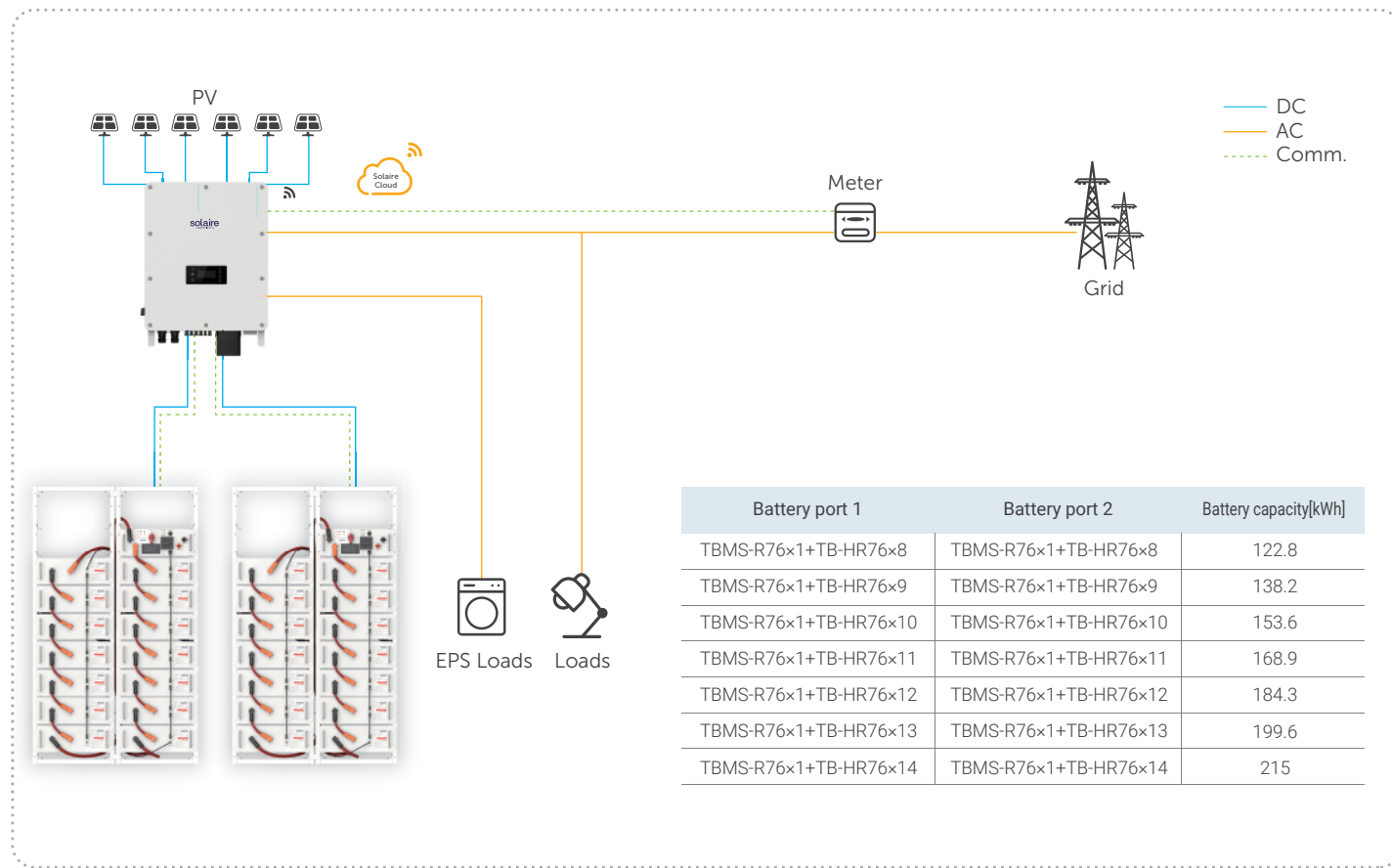
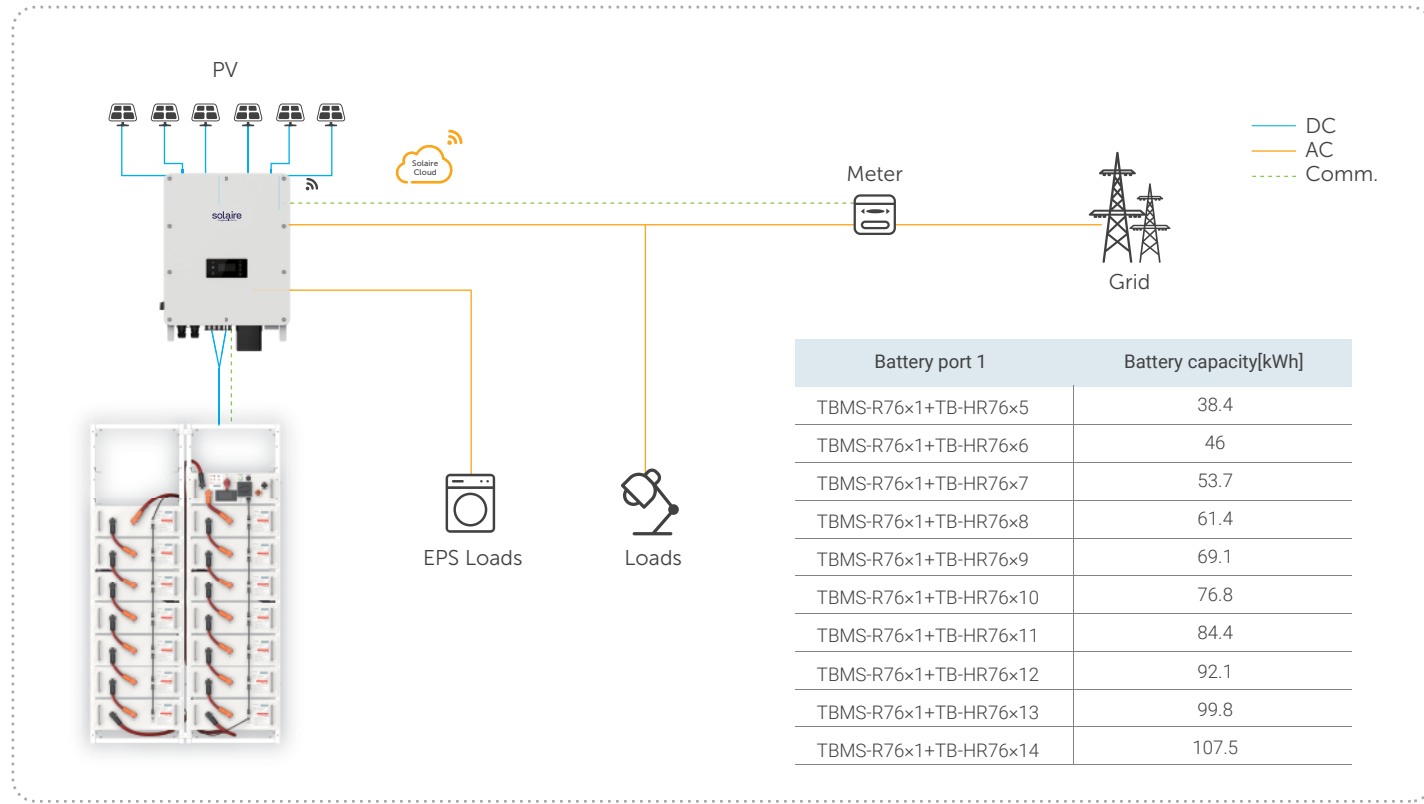

Rated / Maximum operation current and Rated / maximum power derating will occur related to temperature or SOC

solaire

A Lagnuvo Initiative

Powering India's Solar Future

www.solairefuture.com

Global: +86 571-56260008
PL: +48 662 430 292

AU: +61 1300 476 529
DE: +49 (0) 6142 4091 664

UK: +44 2476 586998
NED: +31 (0) 8527 37932

info.solaire@lagnuvo.com
service@solaire@lagnuvo.com

V1.5 Information may be subject to modify without notice.
650.00126.00



AELIO+HR76

49.9kW/50kW/60kW/61kW
38.4kWh-215kWh

Solaire Split C&I Energy Storage Solution

Global: +86 571-56260008

www.solairefuture.com
info.solaire@lagnuvo.com

X3-AELIO



Flexible Configuration

- Customizable battery setup: batteries can be flexibly configured according to customer site requirements, supporting indoor and rack-mounted installations.
- Parallel operation: supports up to 10 parallel systems, meeting power requirements from 49.9 kW to 600 kW on grid.
- Battery options: two-way battery connector, catering to single system capacities ranging from 38.4 kWh to 215 kWh.
- PV oversizing: supports up to 200% PV oversizing.



Safe and Reliable

- Three-phase unbalance: inverter supports 100% three-phase unbalance.
- Long-term overload: inverter supports 110% long-term overload.
- Seamless switching: inverter supports 10ms on-grid/off-grid switching, ensuring uninterrupted power supply for onsite loads.



Intelligent and Convenient

- Remote monitoring: supports web/app remote data viewing and remote OTA updates.
- Versatile operating modes: supports various operating modes to meet different application scenarios such as self-consumption, peak shaving, and demand management.
- VPP integration: supports VPP through IEEE 2030.5, OpenADR.*
- Generator control: work seamlessly with generator to save fuel and back up

* Feature to be upgraded in the future

	X3-AELIO-49.9K	X3-AELIO-49.9K-P	X3-AELIO-50K	X3-AELIO-60K	X3-AELIO-61K
PV INPUT					
Max. recommended PV array power	100 kWp	120 kWp	100 kWp	120 kWp	
Max. PV input voltage ^①	1000 V				
Rated PV input voltage	650 V				
MPPT voltage range ^②	160 ~ 950 V				
Start-up voltage	180 V				
No. of MPP trackers / strings per MPP tracker	5 / 2	6 / 2	5 / 2	6 / 2	
Max. input current per MPPT	40 A				
Max. input short circuit current per MPPT	50 A				
AC INPUT & OUTPUT (ON-GRID)					
Rated output power	49.9 kW	49.9 kW	50 kW	60 kW	61 kW
Rated output current	75.7 A @ 220 V 72.4 A @ 230 V	75.7 A @ 220 V 72.4 A @ 230 V	75.8 A @ 220 V 72.5 A @ 230 V	91.0 A @ 220 V 87.0 A @ 230 V	92.5 A @ 220 V 88.5 A @ 230 V
Max. output apparent power	49.9 kVA	49.9 kVA	55.0 kVA	66.0 kVA	66.0 kVA
Max. output continuous current	75.7 A @ 220 V 72.4 A @ 230 V	75.7 A @ 220 V 72.4 A @ 230 V	83.4 A @ 220 V 79.8 A @ 230 V	100.0 A @ 220 V 95.7 A @ 230 V	100.0 A @ 220 V 95.7 A @ 230 V
Rated AC voltage	3 / N / PE, 220 / 380 V 3 / N / PE, 230 / 400 V				
Rated AC frequency	50 Hz / 60 Hz				
AC frequency range ^③	50 ± 5 Hz / 60 ± 5 Hz				
Adjustable power factor range	~1 (0.8 leading to 0.8 lagging)				
THDi (rated power)	< 3%				

	X3-AELIO-49.9K	X3-AELIO-49.9K-P	X3-AELIO-50K	X3-AELIO-60K	X3-AELIO-61K
BATTERY					
Battery type	LFP				
Battery voltage range	180 ~ 820 V				
Max. charge / discharge current	160 A (80 A × 2)				
EPS (OFF-GRID) OUTPUT					
Rated EPS output voltage, frequency	3 / N / PE, 220 / 380 V, 50 Hz / 60 Hz 3 / N / PE, 230 / 400 V, 50 Hz / 60 Hz				
Rated EPS output power	49.9 kVA	49.9 kVA	50.0 kVA	60.0 kVA	61.0 kVA
Max. EPS output power	75 kVA, 10s	75 kVA, 10s	75 kVA, 10s	90 kVA, 10s	90 kVA, 10s
Switchover time	< 10 ms				
EFFICIENCY					
Max. efficiency	98.0%				
European efficiency	97.2%				
GENERAL					
Ingress protection	IP66				
Operation temperature range	-35 ~ 60°C (derating +45°C)				
Max. operating altitude	3000 m				
Relative humidity	0 ~ 100% RH (condensing)				
Overvoltage category	Mains: III, Battery: II, PV: II				
Dimensions (W × H × D)	670 × 820 × 257 mm				
Net weight	< 100 kg	< 105 kg	< 100 kg	< 105 kg	
Cooling concept	Smart air cooling				
Communication interfaces	RS485-Meter, RS485-Monitor, RS485-Parallel (daisy-chain), CAN-BMS, CAN-Parallel (daisy-chain), USB, DI×2, DO×1, RCR (DI×4), DRM				
Topology	Non-isolated				
Certifications	CE, VDE4105, G99, AS4777, EN50549, CEI 0-21, IEC61727, PEA/MEA, NRS-097-2-1, RD1699, TOR				
PROTECTION					
Over / under voltage protection	Yes				
DC isolation protection	Yes				
DC reverse-polarity protection	Yes				
Grid monitoring	Yes				
DC injection monitoring	Yes				
Back feed current monitoring	Yes				
Residual current detection	Yes				
Over temperature protection	Yes				
Active anti-islanding method	Frequency shift				
Surge protection (DC / AC)	DC: Type II, AC: Type II				
Arc-fault circuit interrupter (AFCI)	Optional				
AC auxiliary power supply (APS)	Built-in				

① The maximum input voltage is the upper limit of the DC voltage. Any higher input DC voltage would probably damage inverter

② Input voltage exceeding the MPPT voltage range may triggers inverter protection

③ The AC frequency range may vary from different country codes

TSYS-HR76

Efficiency

- Delivers sustained 1C performance
- Embedded installation design for rapid deployment
- Modular architecture for streamlined maintenance

Intelligence

- Automated charge/discharge management
- Multi-level protection: overcharge, over-discharge, thermal extremes

Reliability

- High-safety LFP battery
- Extended cycle life for long-term performance

Flexible Configuration

- Scalable battery cluster (5~14 modules per set)
- Remote firmware upgrade support
- Full compatibility with Solaire inverters



SYSTEM SPECIFICATION										
SYS modle name	T-HR38.4 T-HR38.4P ②	T-HR46.0 T-HR46.0P	T-HR53.7 T-HR53.7P	T-HR61.4 T-HR61.4P	T-HR69.2 T-HR69.2P	T-HR76.8 T-HR76.8P	T-HR84.4 T-HR84.4P	T-HR92.1 T-HR92.1P	T-HR99.8 T-HR99.8P	T-HR107.5 T-HR107.5P
Module quantities	5	6	7	8	9	10	11	12	13	14
Nominal energy	38.4 kWh	46.0 kWh	53.7 kWh	61.4 kWh	69.1 kWh	76.8 kWh	84.4 kWh	92.1 kWh	99.8 kWh	107.5 kWh
Usable energy (90%DOD)	34.5 kWh	41.4 kWh	48.3 kWh	55.2 kWh	62.2 kWh	69.1 kWh	76.0 kWh	82.9 kWh	89.8 kWh	96.7 kWh
Nominal voltage	256.0 V	307.2 V	358.4 V	409.6 V	460.8 V	512.0 V	563.2 V	614.4 V	665.6 V	716.8 V
Operating voltage range	200 ~ 292 V	240 ~ 350.4 V	280 ~ 408.8 V	320 ~ 467.2 V	360 ~ 525.6 V	400 ~ 584 V	440 ~ 642.4 V	480 ~ 700.8 V	520 ~ 759.2 V	560 ~ 817.6 V
Recommended charge / discharge current ^①	90 A									
Max. charge / discharge current ^①	150 A									
Rated power	23.0 kW	27.6 kW	32.2 kW	36.8 kW	41.4 kW	46.0 kW	50.6 kW	55.2 kW	59.8 kW	64.5 kW

BATTERY MODULE	
Battery model	TB-HR76
Nominal energy	7.68 kWh
Nominal voltage	51.2 V
Rated capacity	150 Ah
Cycle life (90% DOD)	≥ 6000 (@25°C ± 2°C, 0.5C / 0.5C, 70%EOL)
Battery type	LFP
Dimensions (W x H x D)	450 × 170 × 580 mm
Weight	60 kg

BMS	
BMS model	TBMS-R76
Dimensions (W x H x D)	450 × 180 × 580 mm
Net weight	19.2 kg

RACK	
Dimensions (W x H x D)	530 x 1800 x 600 mm
Weight	38.5 kg
	1110 x 1800 x 600 mm
	77 kg

GENERAL	
Battery roundtrip efficiency (0.5C / 0.5C, 25°C)	95%
Operating temperature range ^①	0 ~ 55°C (charge) -20 ~ 55°C (discharge)
Communication interface	CAN
Installation type	Rack mounting
Relative humidity	5 ~ 85%
Max.operating altitude	3000 m
Environment	Indoor
Safety	IEC 62619, IEC 60730, IEC 63056, IEC 61000
Transport testing requirement	UN38.3

① The current is affected by temperature and SOC.

② The models with "P" are battery systems delivered with rack protection cover